

# Computational Intelligence

Winter Term 2012/13

Prof. Dr. Günter Rudolph

Lehrstuhl für Algorithm Engineering (LS 11)

Fakultät für Informatik

TU Dortmund

- Single-Layer Perceptron
  - Accelerated Learning
  - Online- vs. Batch-Learning
- Multi-Layer-Perceptron
  - Model
  - Backpropagation

## Acceleration of Perceptron Learning

Assumption:  $x \in \{0, 1\}^n \Rightarrow \|x\| \geq 1$  for all  $x \neq (0, \dots, 0)$

If classification incorrect, then  $w'x < 0$ .

Consequently, size of error is just  $\delta = -w'x > 0$ .

$\Rightarrow w_{t+1} = w_t + (\delta + \varepsilon) x$  for  $\varepsilon > 0$  (small) corrects error in a single step, since

$$\begin{aligned}
 w'_{t+1}x &= (w_t + (\delta + \varepsilon) x)' x \\
 &= \underbrace{w'_t x}_{-\delta} + (\delta + \varepsilon) x'x \\
 &= -\delta + \delta \|x\|^2 + \varepsilon \|x\|^2 \\
 &= \underbrace{\delta (\|x\|^2 - 1)}_{\geq 0} + \underbrace{\varepsilon \|x\|^2}_{> 0} > 0 \quad \checkmark
 \end{aligned}$$

**Generalization:**

Assumption:  $x \in \mathbb{R}^n \Rightarrow \|x\| > 0$  for all  $x \neq (0, \dots, 0)$

as before:  $w_{t+1} = w_t + (\delta + \varepsilon) x$  for  $\varepsilon > 0$  (small) and  $\delta = -w'_t x > 0$

$$\Rightarrow w'_{t+1} x = \underbrace{\delta (\|x\|^2 - 1)}_{< 0 \text{ possible!}} + \underbrace{\varepsilon \|x\|^2}_{> 0}$$

Idea: Scaling of data does not alter classification task!

Let  $\ell = \min \{ \|x\| : x \in B \} > 0$

Set  $\hat{x} = \frac{x}{\ell} \Rightarrow$  set of scaled examples  $\hat{B}$

$$\Rightarrow \|\hat{x}\| \geq 1 \Rightarrow \|\hat{x}\|^2 - 1 \geq 0 \Rightarrow w'_{t+1} \hat{x} > 0 \quad \checkmark$$

There exist numerous variants of Perceptron Learning Methods.

**Theorem:** (Duda & Hart 1973)

If rule for correcting weights is  $w_{t+1} = w_t + \gamma_t x$  (if  $w_t' x < 0$ )

1.  $\forall t \geq 0 : \gamma_t \geq 0$

2.  $\sum_{t=0}^{\infty} \gamma_t = \infty$

3.  $\lim_{m \rightarrow \infty} \frac{\sum_{t=0}^m \gamma_t^2}{\left( \sum_{t=0}^m \gamma_t \right)^2} = 0$

then  $w_t \rightarrow w^*$  for  $t \rightarrow \infty$  with  $\forall x' w^* > 0$ . ■

**e.g.:**  $\gamma_t = \gamma > 0$  or  $\gamma_t = \gamma / (t+1)$  for  $\gamma > 0$

**as yet:** *Online Learning*

→ Update of weights after each training pattern (if necessary)

**now:** *Batch Learning*

→ Update of weights only after test of all training patterns

→ Update rule:

$$w_{t+1} = w_t + \gamma \sum_{\substack{w_t^i x < 0 \\ x \in B}} x \quad (\gamma > 0)$$

vague assessment in literature:

- advantage : „usually faster“
- disadvantage : „needs more memory“ ← just a single vector!

**find weights by means of optimization**

Let  $F(w) = \{ x \in B : w'x < 0 \}$  be the set of patterns incorrectly classified by weight  $w$ .

Objective function: 
$$f(w) = - \sum_{x \in F(w)} w'x \rightarrow \min!$$

Optimum:  $f(w) = 0$  iff  $F(w)$  is empty

Possible approach: gradient method

$$w_{t+1} = w_t - \gamma \nabla f(w_t) \quad (\gamma > 0)$$

converges to a local minimum (dep. on  $w_0$ )

## Gradient method

$$w_{t+1} = w_t - \gamma \nabla f(w_t)$$

Gradient points in direction of steepest ascent of function  $f(\cdot)$

Gradient  $\nabla f(w) = \left( \frac{\partial f(w)}{\partial w_1}, \frac{\partial f(w)}{\partial w_2}, \dots, \frac{\partial f(w)}{\partial w_n} \right)$

**Caution:**

Indices  $i$  of  $w_i$  here denote components of vector  $w$ ; they are **not** the iteration counters!

$$\begin{aligned} \frac{\partial f(w)}{\partial w_i} &= -\frac{\partial}{\partial w_i} \sum_{x \in F(w)} w'x = -\frac{\partial}{\partial w_i} \sum_{x \in F(w)} \sum_{j=1}^n w_j \cdot x_j \\ &= - \sum_{x \in F(w)} \underbrace{\frac{\partial}{\partial w_i} \left( \sum_{j=1}^n w_j \cdot x_j \right)}_{x_i} = - \sum_{x \in F(w)} x_i \end{aligned}$$



## Gradient method

thus:

$$\begin{aligned}
 \text{gradient } \nabla f(w) &= \left( \frac{\partial f(w)}{\partial w_1}, \frac{\partial f(w)}{\partial w_2}, \dots, \frac{\partial f(w)}{\partial w_n} \right)' \\
 &= \left( -\sum_{x \in F(w)} x_1, -\sum_{x \in F(w)} x_2, \dots, -\sum_{x \in F(w)} x_n \right)' \\
 &= -\sum_{x \in F(w)} x
 \end{aligned}$$

$$\Rightarrow w_{t+1} = w_t + \gamma \sum_{x \in F(w_t)} x$$

gradient method  $\Leftrightarrow$  batch learning

**How difficult is it**

(a) to find a separating hyperplane, provided it exists?

(b) to decide, that there is no separating hyperplane?

Let  $B = P \cup \{-x : x \in N\}$  (only positive examples),  $w_i \in \mathbb{R}$ ,  $\theta \in \mathbb{R}$ ,  $|B| = m$

For every example  $x_i \in B$  should hold:

$x_{i1} w_1 + x_{i2} w_2 + \dots + x_{in} w_n \geq \theta$  → trivial solution  $w_i = \theta = 0$  to be excluded!

Therefore additionally:  $\eta \in \mathbb{R}$

$x_{i1} w_1 + x_{i2} w_2 + \dots + x_{in} w_n - \theta - \eta \geq 0$

**Idea:**  $\eta$  maximize → if  $\eta^* > 0$ , then solution found

Matrix notation:

$$A = \begin{pmatrix} x'_1 & -1 & -1 \\ x'_2 & -1 & -1 \\ \vdots & \vdots & \vdots \\ x'_m & -1 & -1 \end{pmatrix} \quad z = \begin{pmatrix} w \\ \theta \\ \eta \end{pmatrix}$$

**Linear Programming Problem:**

$$f(z_1, z_2, \dots, z_n, z_{n+1}, z_{n+2}) = z_{n+2} \rightarrow \max!$$

$$\text{s.t. } Az \geq 0$$

calculated by e.g. Kamarkar-  
algorithm in **polynomial time**

If  $z_{n+2} = \eta > 0$ , then weights and threshold are given by  $z$ .

Otherwise separating hyperplane does not exist!

### What can be achieved by adding a layer?

- Single-layer perceptron (SLP)  
⇒ Hyperplane separates space in two subspaces

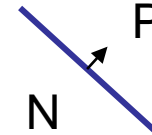

- Two-layer perceptron  
⇒ arbitrary convex sets can be separated

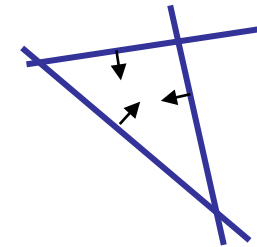

connected by  
AND gate in  
2nd layer

- Three-layer perceptron  
⇒ arbitrary sets can be separated (depends on number of neurons)-

several convex sets representable by 2nd layer,

these sets can be combined in 3rd layer

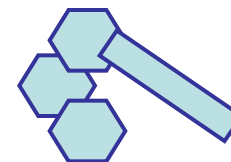

convex sets  
of 2nd layer  
connected by  
OR gate in  
3rd layer

⇒ more than 3 layers not necessary!

## XOR with 3 neurons in 2 steps

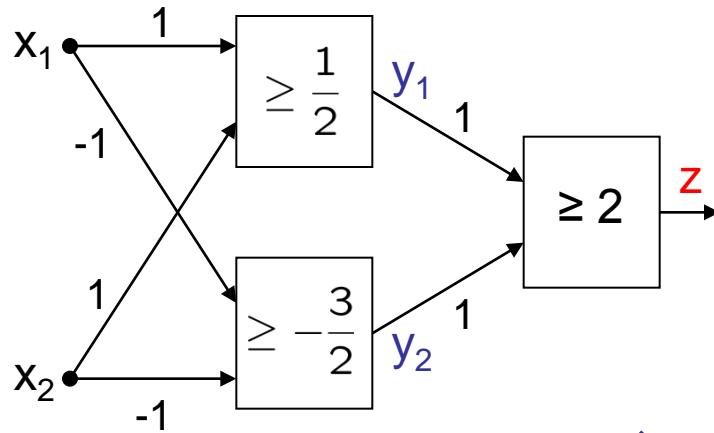

$x_1$	$x_2$	$y_1$	$y_2$	$z$
0	0	0	1	0
0	1	1	1	1
1	0	1	1	1
1	1	1	0	0

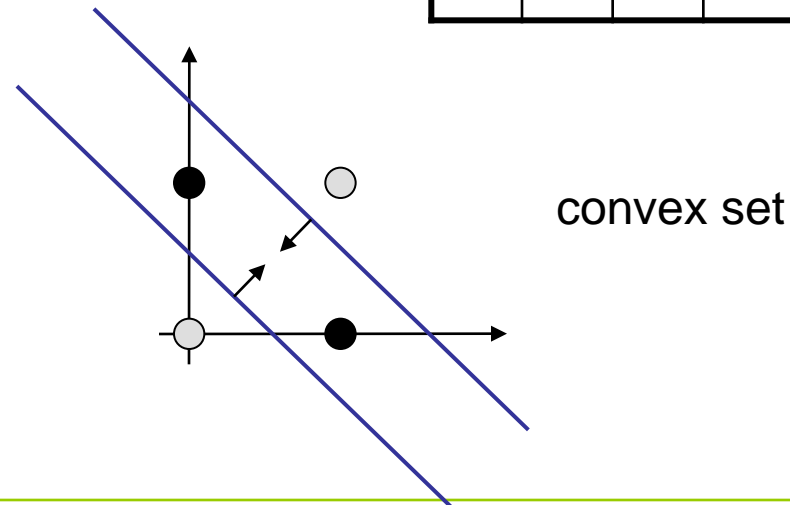

## XOR with 3 neurons in 2 layers

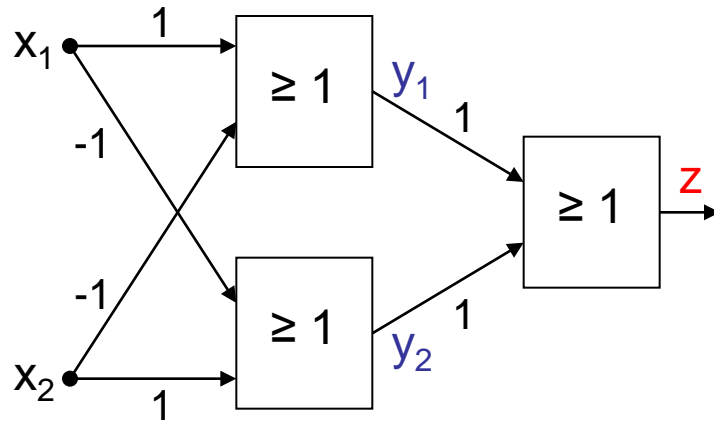

$x_1$	$x_2$	$y_1$	$y_2$	$z$
0	0	0	0	0
0	1	0	1	1
1	0	1	0	1
1	1	0	0	0

without AND gate in 2nd layer

$$\left. \begin{array}{l} x_1 - x_2 \geq 1 \\ x_2 - x_1 \geq 1 \end{array} \right\} \Leftrightarrow \begin{cases} x_2 \leq x_1 - 1 \\ x_2 \geq x_1 + 1 \end{cases}$$

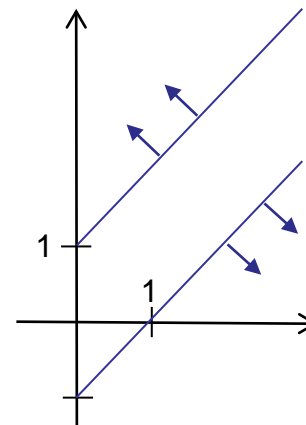

XOR can be realized with only 2 neurons!

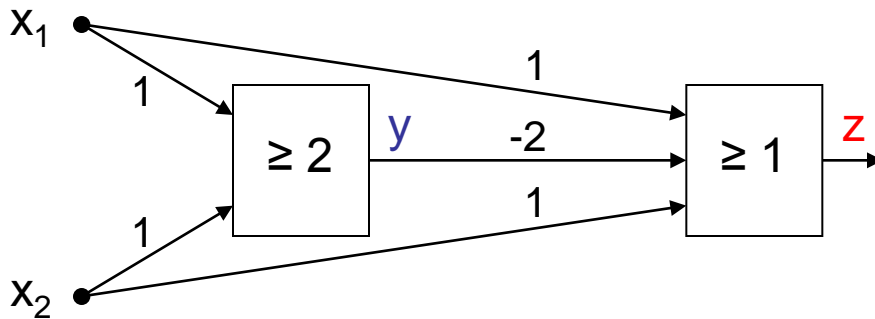

$x_1$	$x_2$	$y$	$-2y$	$x_1 - 2y + x_2$	$z$
0	0	0	0	0	0
0	1	0	0	1	1
1	0	0	0	1	1
1	1	1	-2	0	0

**BUT:** this is not a layered network (no MLP) !

### **Evidently:**

MLPs deployable for addressing significantly more difficult problems than SLPs!

### **But:**

How can we adjust all these weights and thresholds?

Is there an efficient learning algorithm for MLPs?

### **History:**

Unavailability of efficient learning algorithm for MLPs was a brake shoe ...

... until **Rumelhart, Hinton and Williams (1986): Backpropagation**

Actually proposed by **Werbos (1974)**

... but unknown to ANN researchers (was PhD thesis)



## Quantification of classification error of MLP

- Total Sum Squared Error (TSSE)

$$f(w) = \sum_{x \in B} \underbrace{\|g(w; x)\|}_{\text{output of net for weights } w \text{ and input } x} - \underbrace{g^*(x)}_{\text{target output of net for input } x} \|^2$$

output of net for weights  $w$  and input  $x$       target output of net for input  $x$

- Total Mean Squared Error (TMSE)

$$f(w) = \frac{1}{|B| \cdot \ell} \sum_{x \in B} \|g(w; x) - g^*(x)\|^2 = \underbrace{\frac{1}{|B| \cdot \ell}}_{\text{const.}} \cdot \text{TSSE}$$

# training patterns

# output neurons

⇒ leads to same solution as TSSE

### Learning algorithms for Multi-Layer-Perceptron (here: 2 layers)

**idea:** minimize error!

$$f(w_t, u_t) = \text{TSSE} \rightarrow \min!$$

#### Gradient method

$$u_{t+1} = u_t - \gamma \nabla_u f(w_t, u_t)$$

$$w_{t+1} = w_t - \gamma \nabla_w f(w_t, u_t)$$

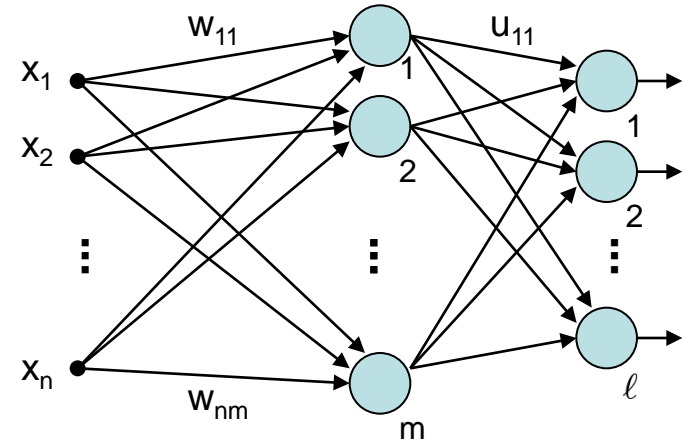

**BUT:**

$f(w, u)$  cannot be differentiated!

Why?  $\rightarrow$  Discontinuous activation function  $a(\cdot)$  in neuron!

$$a(x) = \begin{cases} 1 & \text{if } x > \theta \\ 0 & \text{otherwise} \end{cases}$$

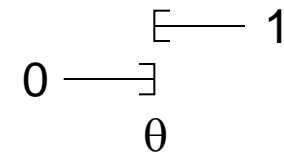

**idea:** find **smooth** activation function similar to original function !

## Learning algorithms for Multi-Layer-Perceptron (here: 2 layers)

good idea: sigmoid activation function (instead of signum function)

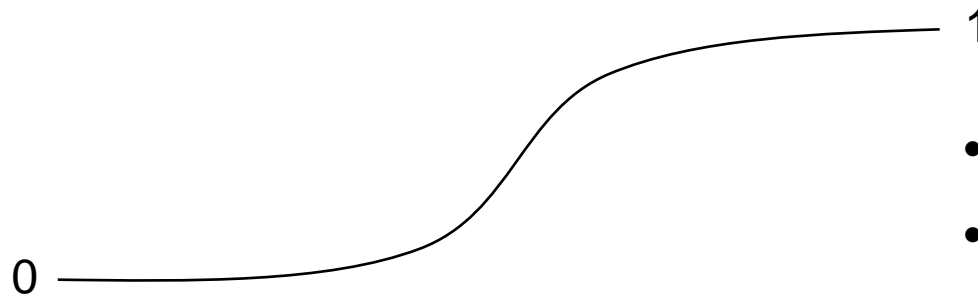
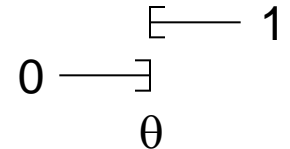

- monotone increasing
- differentiable
- non-linear
- output  $\in [0,1]$  instead of  $\in \{ 0, 1 \}$
- threshold  $\theta$  integrated in activation function

e.g.:

- $a(x) = \frac{1}{1 + e^{-x}}$        $a'(x) = a(x)(1 - a(x))$
  - $a(x) = \tanh(x)$        $a'(x) = (1 - a^2(x))$
- } values of derivatives directly determinable from function values

### Learning algorithms for Multi-Layer-Perceptron (here: 2 layers)

#### Gradient method

$$f(w_t, u_t) = \text{TSSE}$$

$$u_{t+1} = u_t - \gamma \nabla_u f(w_t, u_t)$$

$$w_{t+1} = w_t - \gamma \nabla_w f(w_t, u_t)$$

$x_i$ : inputs

$y_j$ : values after first layer

$z_k$ : values after second layer

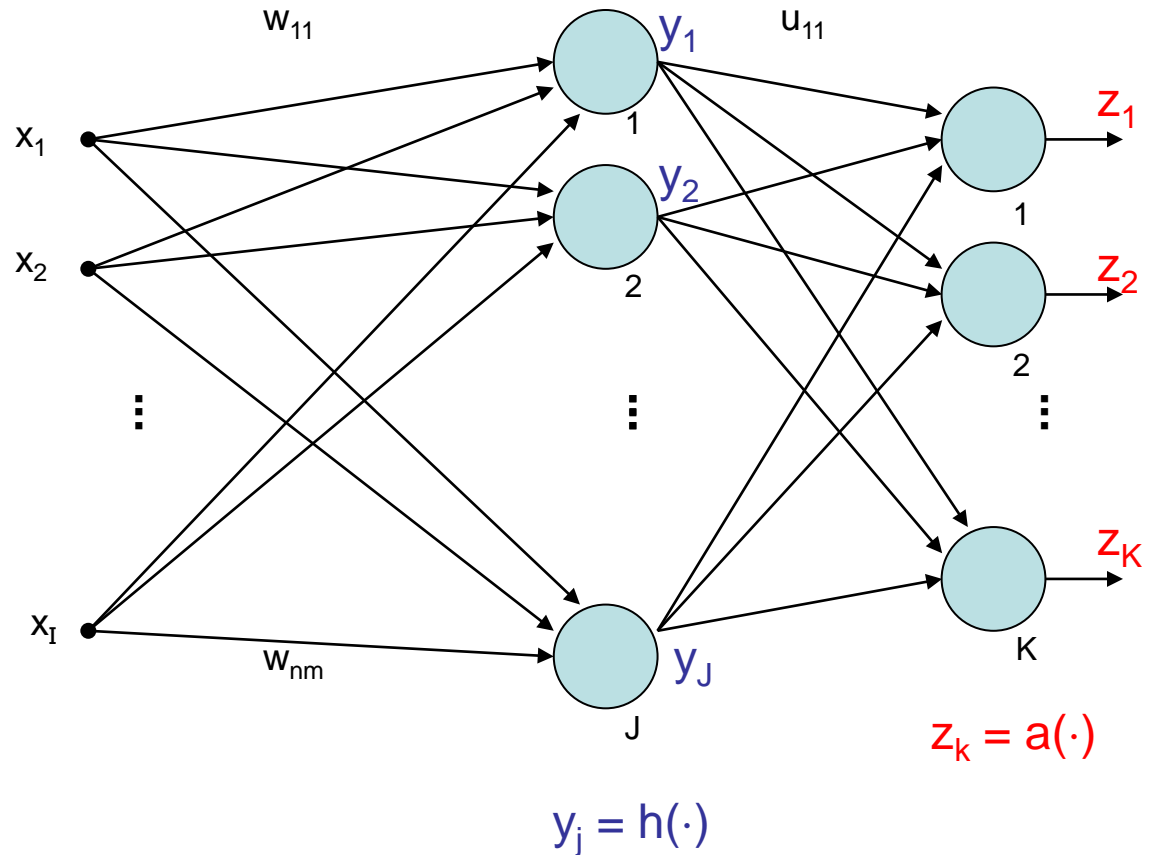

$$y_j = h \left( \sum_{i=1}^I w_{ij} \cdot x_i \right) = h(w'_j x)$$

output of neuron j  
after 1st layer

$$z_k = a \left( \sum_{j=1}^J u_{jk} \cdot y_j \right) = a(u'_k y)$$

output of neuron k  
after 2nd layer

$$= a \left( \sum_{j=1}^J u_{jk} \cdot h \left( \sum_{i=1}^I w_{ij} \cdot x_i \right) \right)$$

error of input x:

$$f(w, u; x) = \sum_{k=1}^K (z_k(x) - z_k^*(x))^2 = \sum_{k=1}^K (z_k - z_k^*)^2$$

output of net

target output for input x

error for input  $x$  and target output  $z^*$ :

$$f(w, u; x, z^*) = \sum_{k=1}^K \left[ \underbrace{a \left( \sum_{j=1}^J u_{jk} \cdot \underbrace{h \left( \sum_{i=1}^I w_{ij} \cdot x_i \right)}_{y_j} \right)}_{z_k} - z_k^*(x) \right]^2$$

$w'_j x$

total error for all training patterns  $(x, z^*) \in B$ :

$$f(w, u) = \sum_{(x, z^*) \in B} f(w, u; x, z^*) \quad (\text{TSSE})$$

**gradient of total error:**

$$\nabla f(w, u) = \sum_{(x, z^*) \in B} \nabla f(w, u; x, z^*)$$

vector of partial derivatives w.r.t.  
weights  $u_{jk}$  and  $w_{ij}$

**thus:**

$$\frac{\partial f(w, u)}{\partial u_{jk}} = \sum_{(x, z^*) \in B} \frac{\partial f(w, u; x, z^*)}{\partial u_{jk}}$$

**and**

$$\frac{\partial f(w, u)}{\partial w_{ij}} = \sum_{(x, z^*) \in B} \frac{\partial f(w, u; x, z^*)}{\partial w_{ij}}$$

**assume:**  $a(x) = \frac{1}{1 + e^{-x}} \Rightarrow \frac{d a(x)}{d x} = a'(x) = a(x) \cdot (1 - a(x))$

**and:**  $h(x) = a(x)$

**chain rule of differential calculus:**

$$[p(q(x))]' = \underbrace{p'(q(x))}_{\text{outer derivative}} \cdot \underbrace{q'(x)}_{\text{inner derivative}}$$



$$f(w, u; x, z^*) = \sum_{k=1}^K [a(u'_k y) - z_k^*]^2$$

**partial derivative w.r.t.  $u_{jk}$ :**

$$\begin{aligned} \frac{\partial f(w, u; x, z^*)}{\partial u_{jk}} &= 2 [a(u'_k y) - z_k^*] \cdot a'(u'_k y) \cdot y_j \\ &= 2 [a(u'_k y) - z_k^*] \cdot a(u'_k y) \cdot (1 - a(u'_k y)) \cdot y_j \\ &= \underbrace{2 [z_k - z_k^*] \cdot z_k \cdot (1 - z_k)}_{\text{"error signal" } \delta_k} \cdot y_j \end{aligned}$$

partial derivative w.r.t.  $w_{ij}$ :

$$\begin{aligned} \frac{\partial f(w, u; x, z^*)}{\partial w_{ij}} &= 2 \sum_{k=1}^K \underbrace{[a(u'_k y) - z_k^*]}_{z_k} \cdot \underbrace{a'(u'_k y)}_{z_k(1-z_k)} \cdot u_{jk} \cdot \underbrace{h'(w'_j x)}_{y_j(1-y_j)} \cdot x_i \\ &= 2 \cdot \sum_{k=1}^K [z_k - z_k^*] \cdot z_k \cdot (1 - z_k) \cdot u_{jk} \cdot y_j (1 - y_j) \cdot x_i \\ &\stackrel{\text{factors reordered}}{=} x_i \cdot y_j \cdot (1 - y_j) \cdot \underbrace{\sum_{k=1}^K 2 \cdot [z_k - z_k^*] \cdot z_k \cdot (1 - z_k) \cdot u_{jk}}_{\text{error signal } \delta_k \text{ from previous layer}} \\ &\quad \underbrace{\hspace{15em}}_{\text{error signal } \delta_j \text{ from "current" layer}} \end{aligned}$$

**Generalization** (> 2 layers)

Let neural network have L layers  $S_1, S_2, \dots, S_L$ .

Let neurons of all layers be numbered from 1 to N.

}  $j \in S_m \rightarrow$   
neuron j is in  
m-th layer

All weights  $w_{ij}$  are gathered in weights matrix W.

Let  $o_j$  be output of neuron j.

error signal:

$$\delta_j = \begin{cases} o_j \cdot (1 - o_j) \cdot (o_j - z_j^*) & \text{if } j \in S_L \text{ (output neuron)} \\ o_j \cdot (1 - o_j) \cdot \sum_{k \in S_{m+1}} \delta_k \cdot w_{jk} & \text{if } j \in S_m \text{ and } m < L \end{cases}$$

correction:

$$w_{ij}^{(t+1)} = w_{ij}^{(t)} - \gamma \cdot o_i \cdot \delta_j$$

in case of online learning:

correction after **each** test pattern presented

error signal of neuron in inner layer determined by

- error signals of all neurons of subsequent layer and
- weights of associated connections.



- First determine error signals of output neurons,
- use these error signals to calculate the error signals of the preceding layer,
- use these error signals to calculate the error signals of the preceding layer,
- and so forth until reaching the first inner layer.



thus, error is propagated backwards from output layer to first inner  
⇒ **backpropagation** (of error)

⇒ other optimization algorithms deployable!

in addition to **backpropagation** (gradient descent) also:

- **Backpropagation with Momentum**

take into account also previous change of weights:

$$\Delta w_{ij}^{(t)} = -\gamma_1 \cdot o_i \cdot \delta_j - \gamma_2 \cdot \Delta w_{ij}^{(t-1)}$$

- **QuickProp**

assumption: error function can be approximated locally by quadratic function,  
update rule uses last two weights at step  $t - 1$  and  $t - 2$ .

- **Resilient Propagation (RPROP)**

exploits sign of partial derivatives:

2 times negative or positive ⇒ increase step!

change of sign ⇒ reset last step and decrease step!

typical values: factor for decreasing 0,5 / factor of increasing 1,2

- **evolutionary algorithms**

individual = weights matrix

} later more  
about this!